

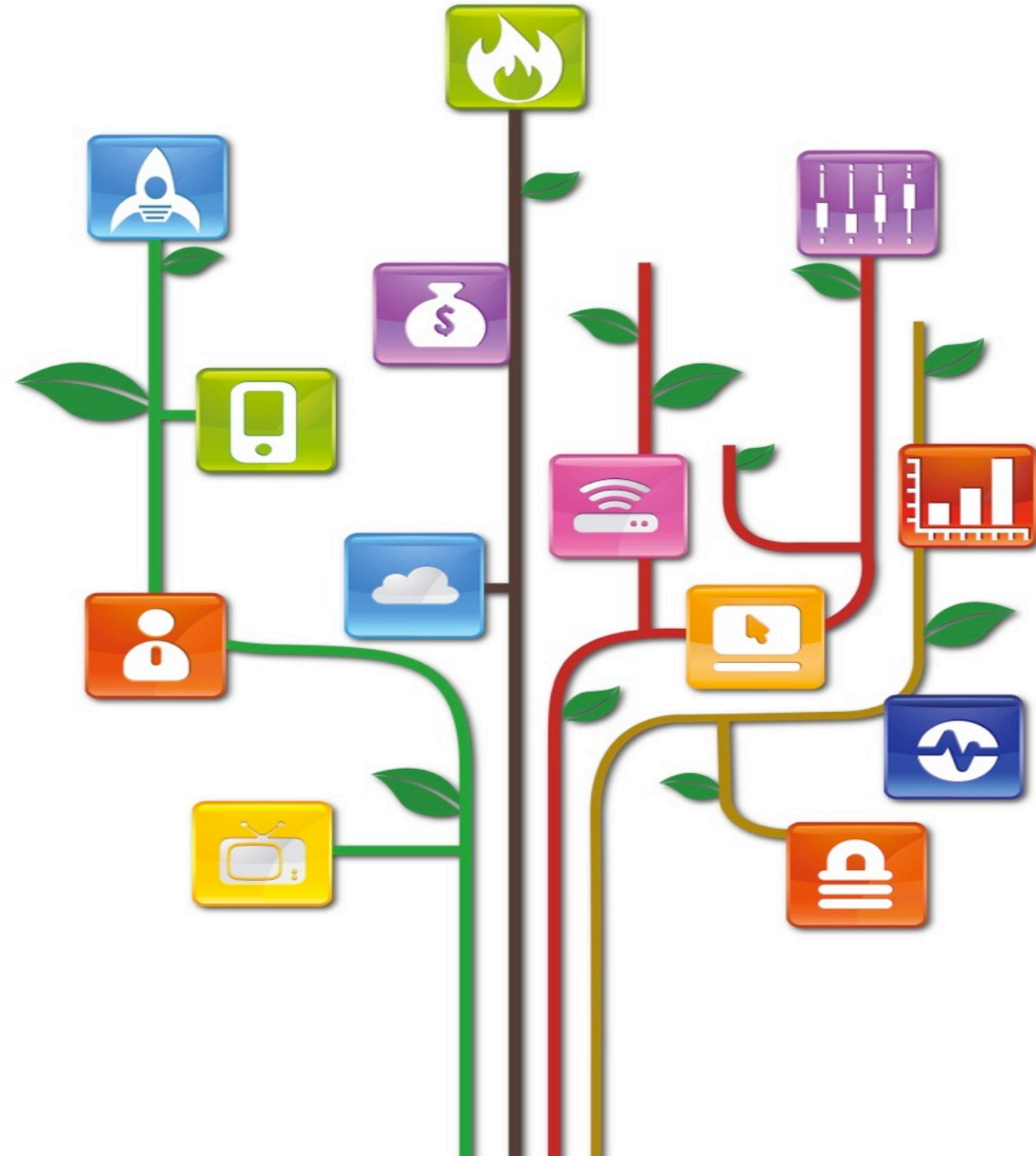

inform innovate accelerate optimize

TM FORUM APIs

Pierre Gauthier
TM Forum Chief API Architect
pgauthier@tmforum.org



TMF Forum APIs...

A family of APIs making it easier to

- create
- build
- and operate

complex, innovative services

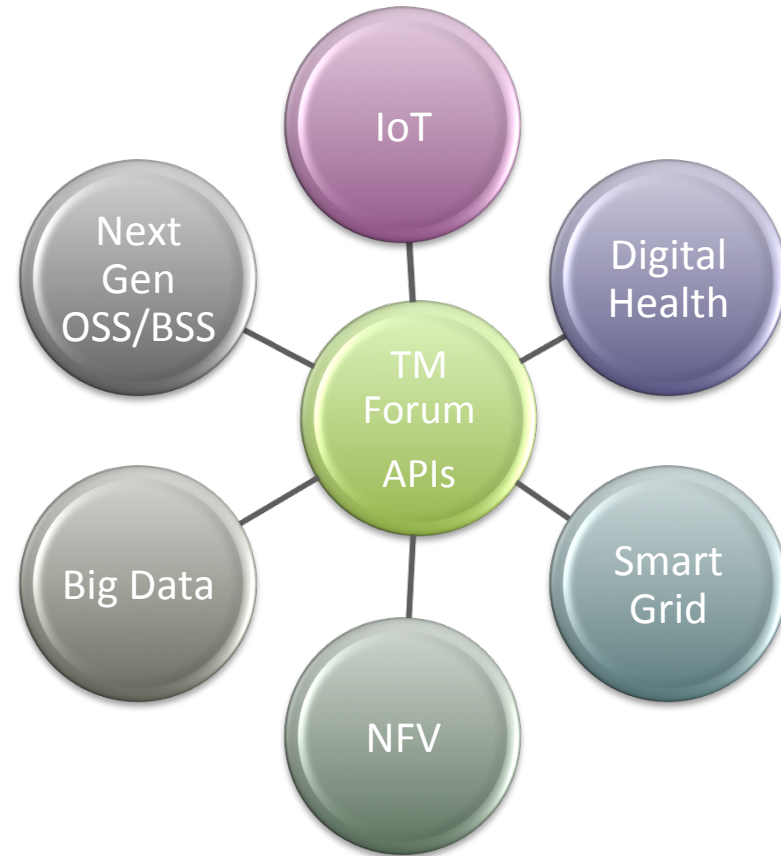

REST based

TMF API Ecosystem

Product
Ordering
API

Product
Catalog
API

Product
Inventory
API

Billing
API

Service
Catalog
API

Performance
API

SLA
Management
API

Trouble
Ticket
API

Onboarding
API

Federated
Identity
API

Service
Activation
And
Provisioning
API

From IoT Device Management
to
Complex B2B Value Fabrics

End to End APIs...

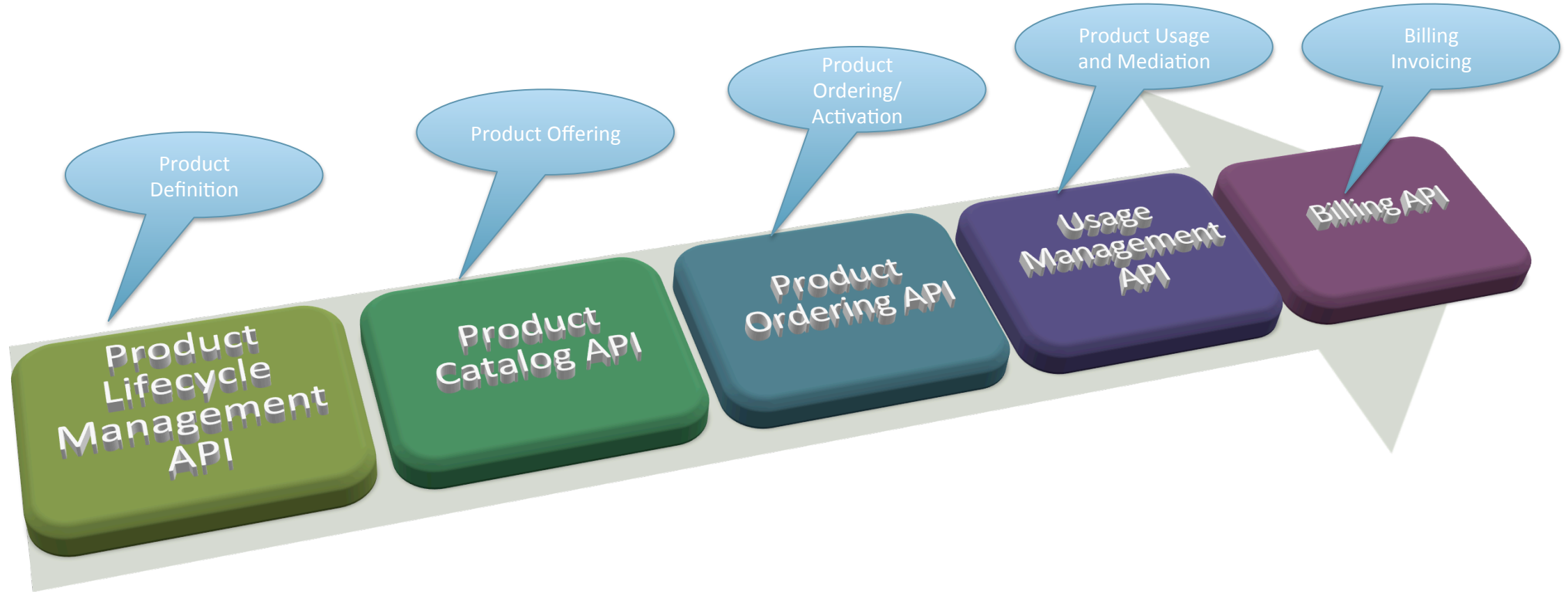

Simple Data Model with Hyperlinks...

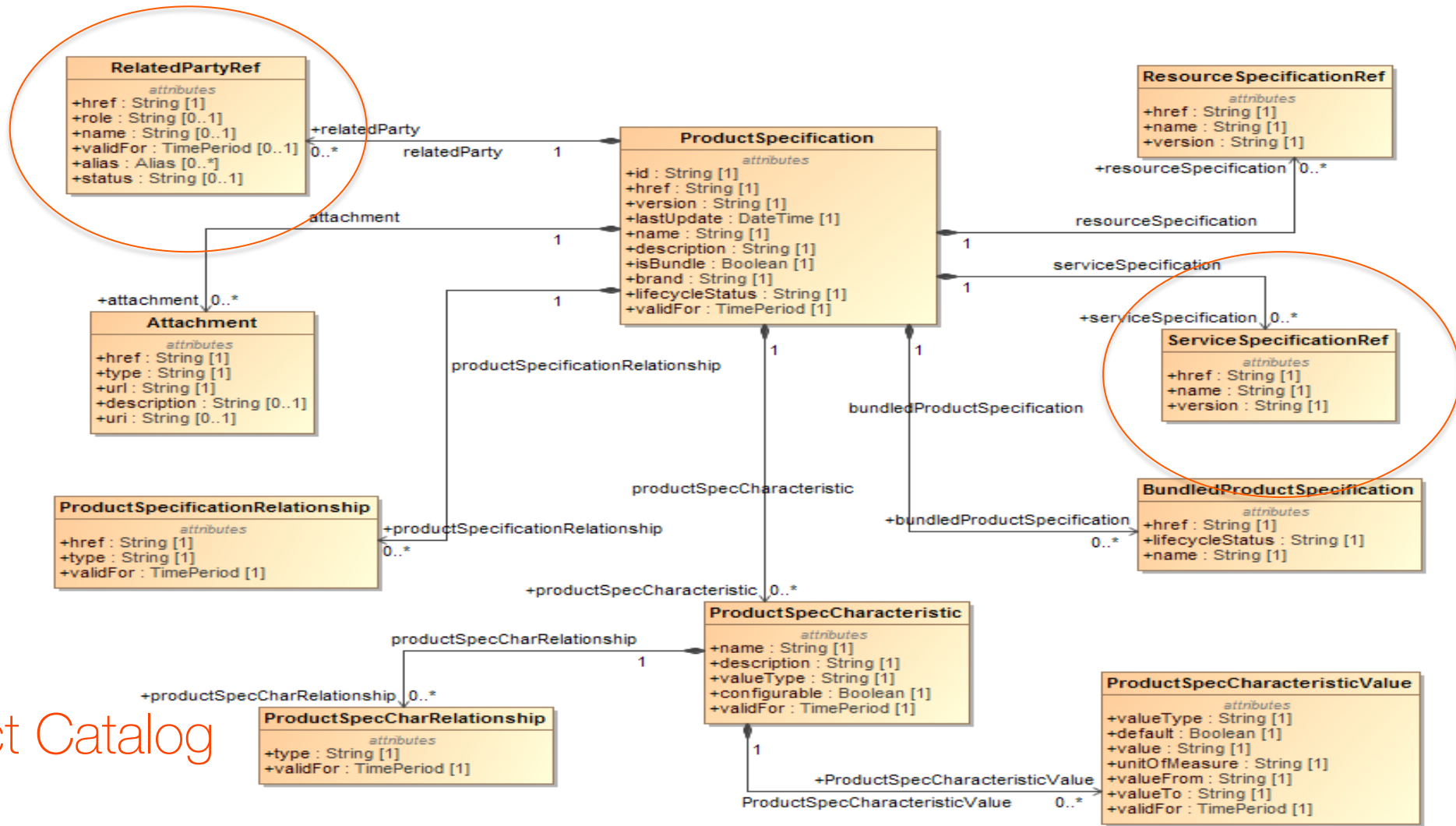

Product Catalog
API

Related Party is an Organization...

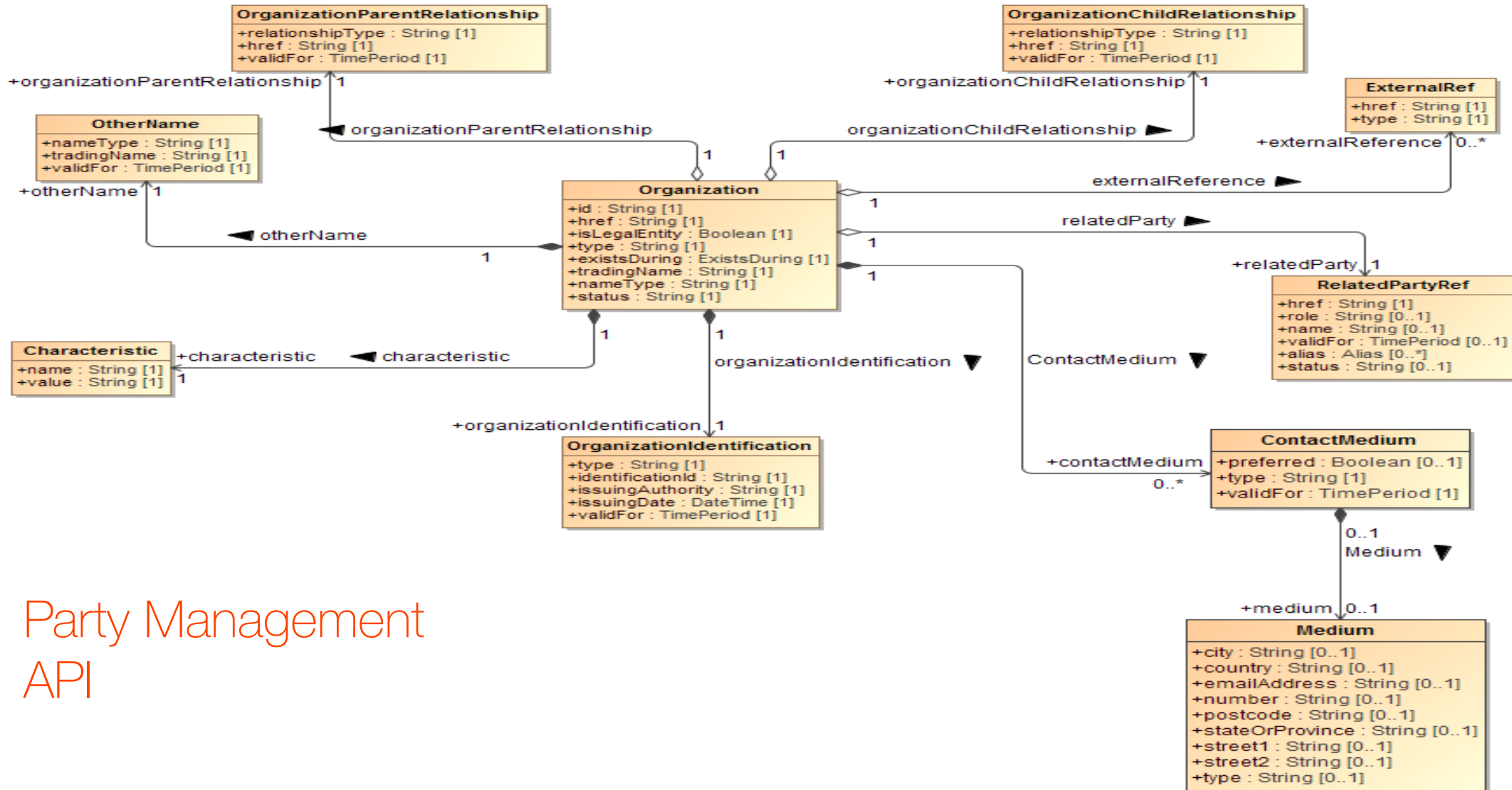

Party Management
API

API Inventory Q4 2014

- **TMF629 Customer Management API**
 - The customer management API provides standardized mechanism for customer and customer account management, such as creation, update, retrieval, deletion and notification of events.
- **TMF632 Party Management API**
 - The party management API provides standardized mechanism for party management such as creation, update, retrieval, deletion and notification of events.
 - Party can be an individual or an organization that has any kind of relation with the enterprise.
- **TMF634 Resource Catalog Management API**
 - The Resource Catalog Management API provides a standardized solution for adding rapidly Resource Specifications to an existing Catalog.
- **TMF633 Service Catalog Management API**
 - The Service Catalog Management API provides a standardized solution for adding rapidly partners' Service Specification to an existing Catalog.
- **TMF635 Usage API**
 - The usage API provides standardized mechanism for usage management such as creation, update, retrieval, import and export of a collection of usages.
- **TMF637 Product Inventory Management API**
 - The Product Inventory API provides standardized mechanism for product inventory management such as creation, partial or full update and retrieval of the representation of a product in the inventory. It also allows the notification of events related to product lifecycle.

API Inventory 2014

- TMF636 Billing Account Management, Invoices and Settlements API
 - The Billing API provides standardized mechanisms for billing account, bill item and settlement note advice management either in B2B or B2B2C contexts.
- TMF638 Service Inventory Management API
 - The Service Inventory API provides standardized mechanism for service inventory management such as creation, partial or full update and retrieval of the representation of a service in the inventory. It allows also notification of events related to service lifecycle.
- TMF639 Resource Inventory Management API
 - The Resource Inventory API provides standardized mechanism for resource inventory management such as creation, partial or full update and retrieval of the representation of a resource in the inventory. It allows also notification of events related to resource lifecycle.
- TMF623 SLA Management API
 - The SLA API provides a standardized interface for SLA life cycle Management (SLA Negotiation, SLA configuration SLA Activation/enforcement, SLA Operations, SLA violation / consequence handling, SLA reporting) between a Customer and a Service Provider which provides offers (product with attached SLA in its catalogue) the customer can discover, browse, trigger and order.
- TMF628 Performance Management API
 - The performance management API provides standardized mechanism for performance management such as creation, partial or full update and retrieval of the resources involved in performance management (Measurement Production Job, Measurement Collection Job, and Ad hoc Collection).

API Inventory Q4 2014

- **TMF622 Product Ordering API**
 - The Product Ordering API provides a standardized mechanism for placing a product order with all of the necessary order parameters.
- **TMF620 Product Catalog Management API**
 - The Product Catalog Management API provides a standardized solution for adding rapidly partners' products to an existing Catalog.
 - It brings the capability for Service Providers to directly feed partners systems with the technical description of the products they propose to them.
- **TMF621 Trouble Ticket API**
 - The Trouble ticketing API provides a standardized client interface to Trouble Ticket Management Systems for creating, tracking and managing trouble tickets among partners as a result of an issue or problem identified by a customer or another system.

Forum APIs are for Developers...

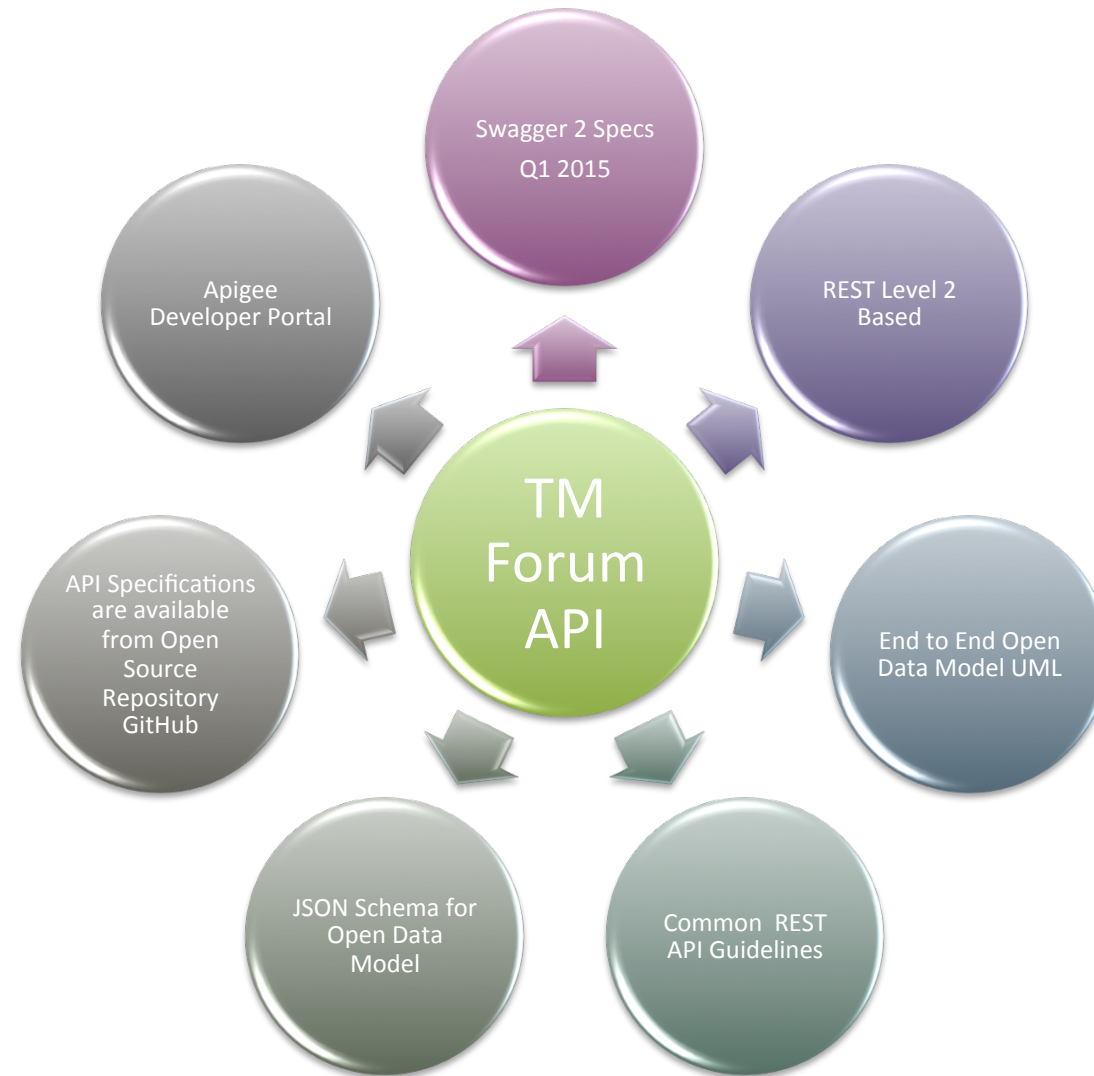

APIGEE
Console and Proxy



API Sandbox running on the
Cloud

Service: http://env-4126955.jelastic.sei Authentication: No Auth powered by **apigee**

Select an API method

Search methods...

Trouble Ticket

- GET /troubleTicket
- POST /troubleTicket
- GET /troubleTicket/{id}
- POST PATCH via X-HTTP-Method-Override on POST
- PUT /troubleTicket/{id}

Hub

- POST /hub
- GET /hub
- GET /hub/{id}
- DELETE /hub/{id}

api/troubleTicket Send

Response Snapshot

1

```
HTTP/1.1 200 OK
Date: Sun, 01 Jun 2014 19:49:31 GMT
Transfer-Encoding: chunked
Content-Type: application/json
Server: GlassFish Server Open Source Edition 3.1.2
X-Powered-By: Servlet/3.0 JSP/2.2 (GlassFish Server Open Source Edition 3.1.2 Java/Oracle Corporation/1.7)

[
  {
    "id": "1",
    "description": "Some Description",
    "severity": "Medium",
    "type": "CspOrange",
    "creationDate": "2013-10-20T02:30:30UTC",
    "targetResolutionDate": "2013-09-16T16:39:28UTC",
    "status": "Resolved",
    "statusChangeReason": "Forwarded to CSP",
    "statusChangeDate": "2013-10-20T16:57:24UTC",
    "resolutionDate": "2013-09-16T16:39:28",
    "relatedObjects": [
      {
        "reference": "referenceobject",
        "involvement": "involvement"
      }
    ]
  }
]
```

Forum APIs Sandbox and Testing...

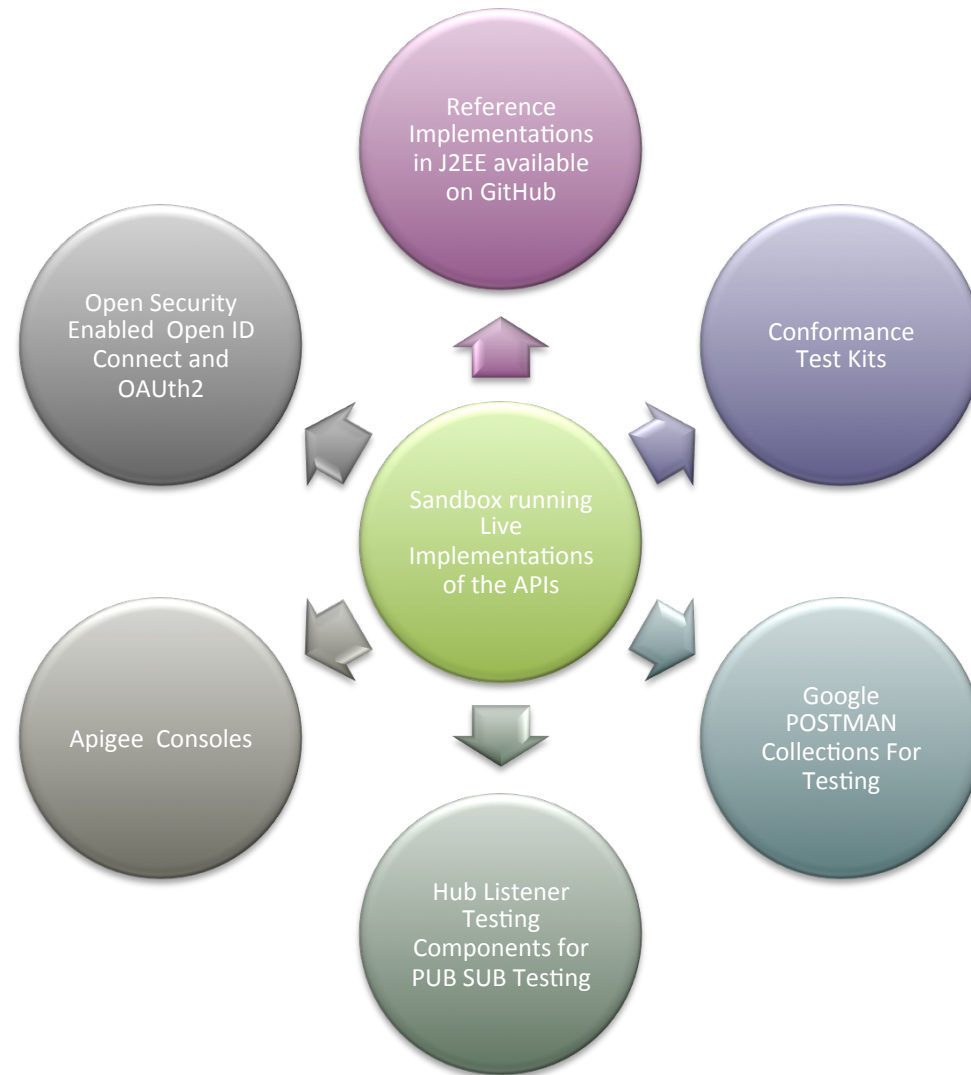

<https://github.com/tmforum>



tmforum

Filters ▾ Find a repository...

DSMSLA-API
TM Forum SLA Management API
Updated on Apr 24

DSMPMAPI
TMF Performance Management REST API
Updated on Dec 19, 2013

DSMCUST PRIVATE
Customer Management API
Updated on Dec 4, 2013

DSPRODUCTORDERING
TM Forum Product Ordering API Git Repository

Open Source GitHub and REST Based

Spec Tooling

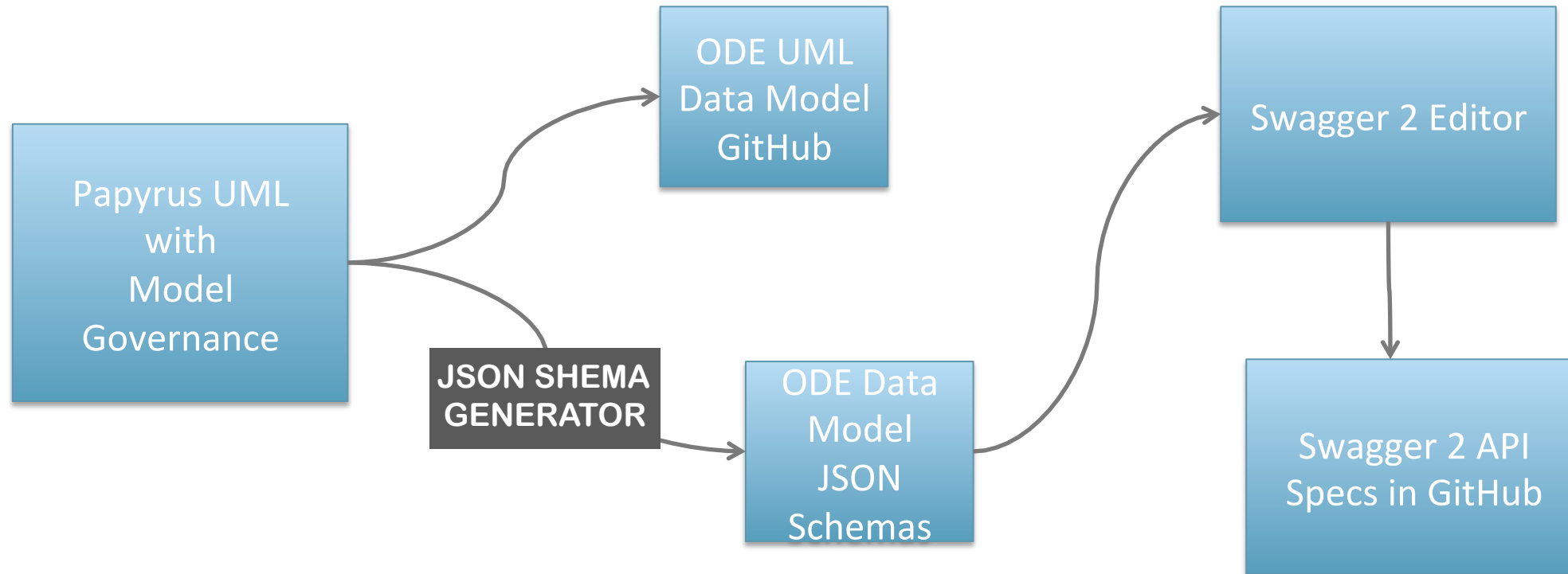

Implementation Tooling

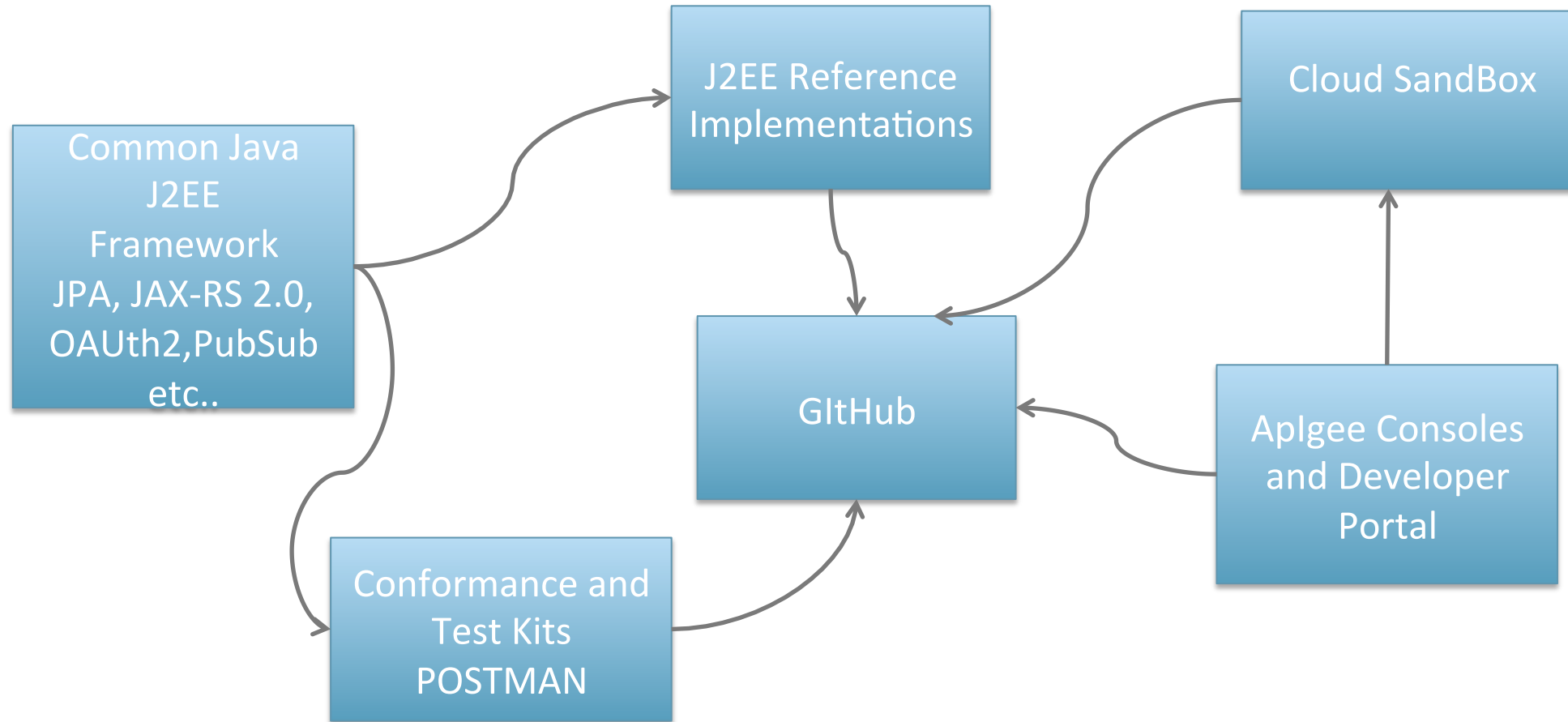

TMF APIS ARE SERVICE AGNOSTIC

- TMF APIs are generic framework APIs which can be used for any type of L2/L3/etc service for the communications industry as well as other industries.
- Any Service deployed in the TMF API Ecosystem can be instrumented with a set of generic APIs
- Service can be:
 - Ordered via the Service Ordering API
 - Activated and Provisioned via Service Activation and Provisioning API
 - Offered in Service Catalog via Service Catalog API
 - Hyperlinked to Product Offerings in Product Catalogs via Product Catalog API
 - Hyperlinked to Service Level Agreement in SLA Management System supporting SLA APIs

Generic ODE Service Model

- TMF is not developing MEF Carrier Ethernet Service Order, Configuration and Activation APIs.
- TMF and MEF are looking at how to implement/map the MEF Service Model so that the TMF Generic APIs can be used i.e Catalog, SLA, Ordering, Configuration etc...
- MEF Service State Model follow core Service State Model
- MEF Service Specification with configurable and fixed Characteristics
- MEF ServiceConfigSpec shaping the possible Service Configurations
- This is being worked on and should be available as a working draft December 2014

ODE Generic Service in the API Ecosystem...

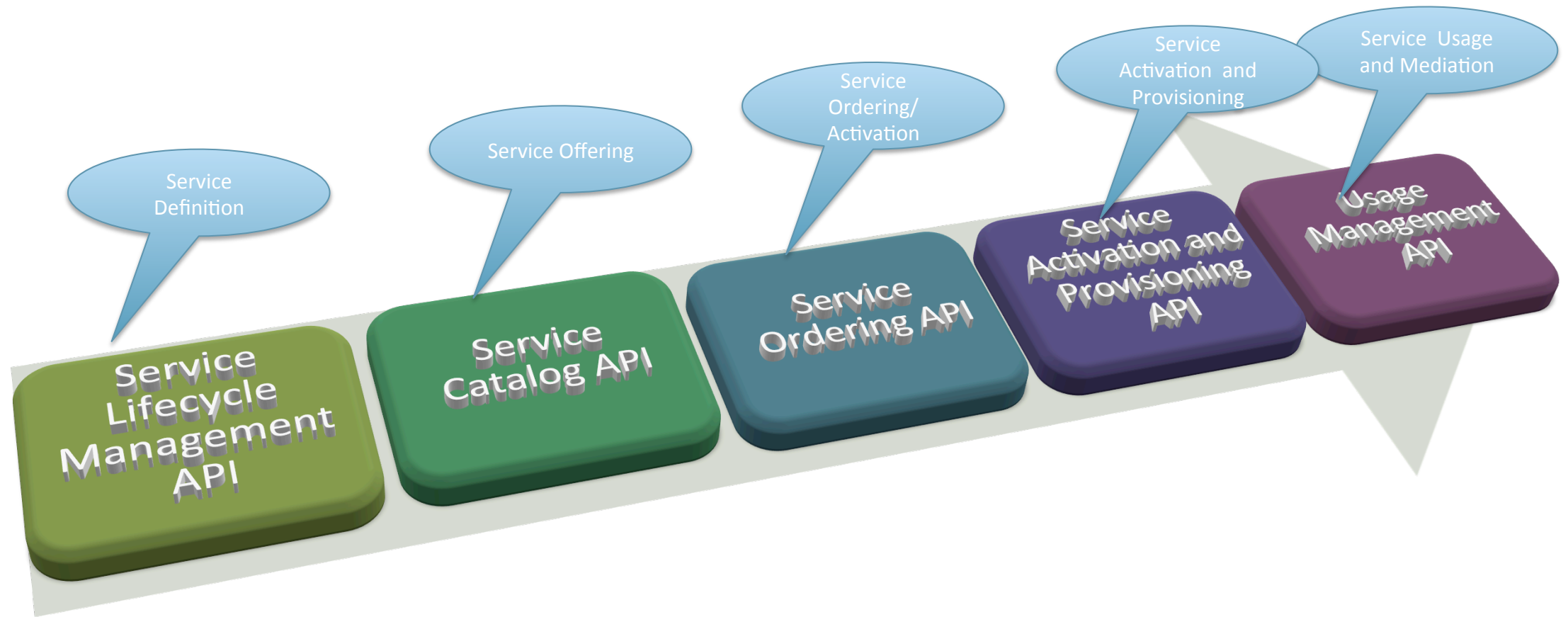

API Roadmap Q4 2014

- Service Ordering APIs –Q1 2015
- Service Activation and Provisioning APIs – Q1 2015
- Pre-ordering Processes
- Order Validation, Feasibility etc...
 - Quotes
 - Appointments
 - Qualification
- Service Quality Management
 - SLO Thresholds Alarms etc..
- Federated identity / profile, privacy
- Partner on-boarding APIs Agreements
- OTT API

E2E API Use Cases...

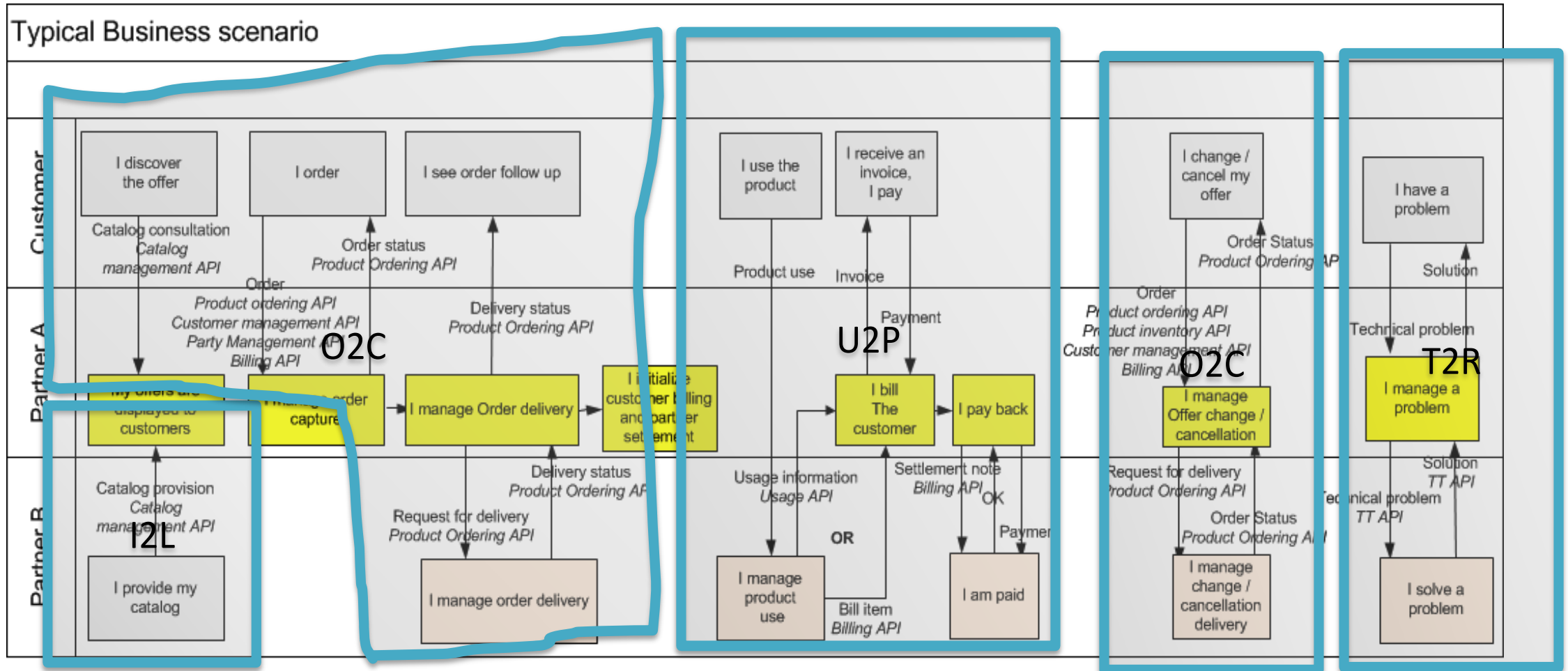

NFV and the TMF API Ecosystem...

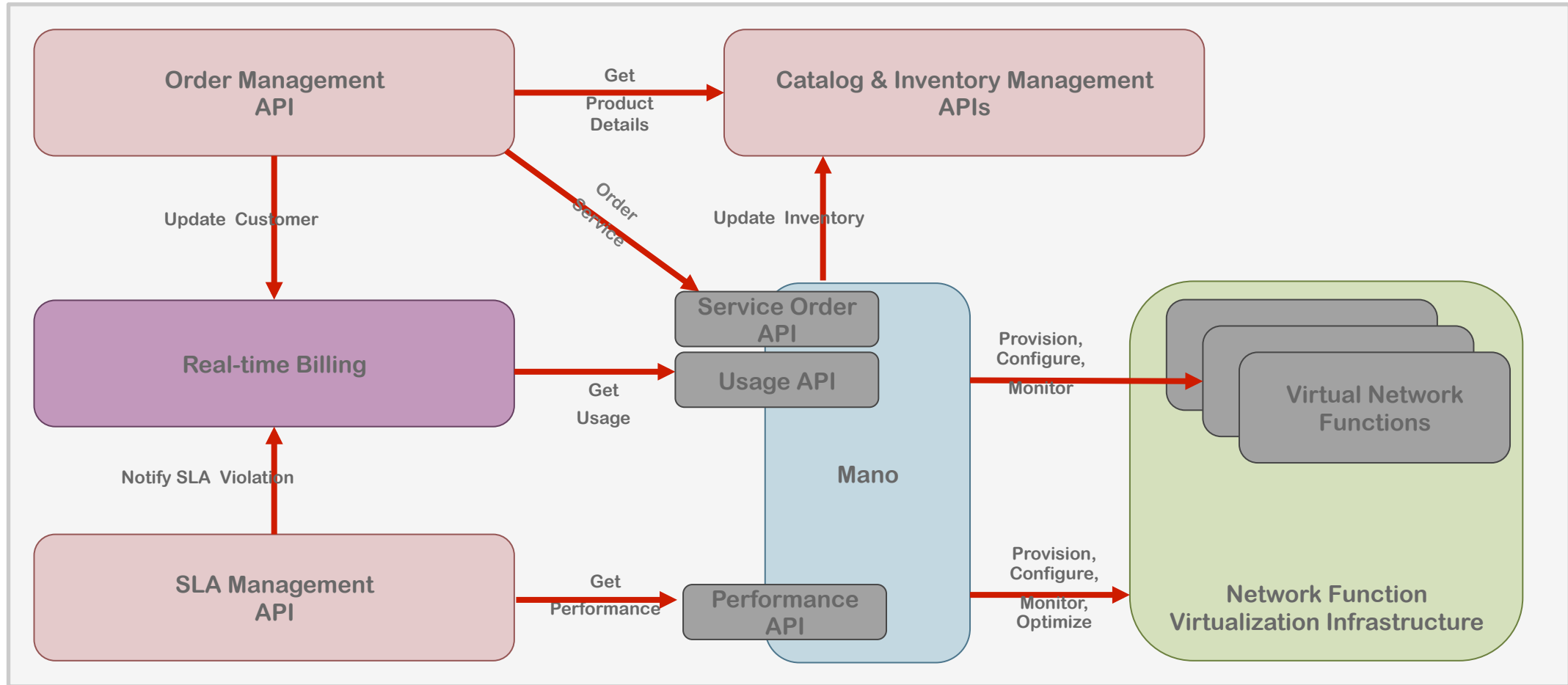

APIs and Ecosystems Priority for 2015

